

## FORM A

**Instructions:** On your opscan sheet, enter your NAME, your ID NUMBER, and the FORM DESIGNATION (A, B, or C). Enter your CRN in the box marked “Course Ref.” Fill in the bubbles under your ID number and form designation.

Answer all questions using a number two pencil; machine grading may ignore faintly marked circles. Use rows 1–16 of the opscan sheet. Calculators are *not* permitted. You have one hour.

Write your name and sign the honor pledge below.

I have neither given nor received unauthorized assistance on this examination.

Name: (Print) \_\_\_\_\_ Signature: \_\_\_\_\_

1. Consider the curve whose parameterization is shown below and whose graph is shown to the right. Compare the curvature at points A, B, and C, and place the curvature at these points in order from the smallest to the largest numeric value.

$$\begin{cases} x = \csc(2t) \sin(8t) \\ y = 2 \csc(2t) \sin(3t) \sin(5t) \\ 0 < t < \pi \end{cases}$$

- ①  $\kappa_C < \kappa_A < \kappa_B$   
 ②  $\kappa_A < \kappa_B < \kappa_C$   
 ③  $\kappa_B < \kappa_A < \kappa_C$   
 ④  $\kappa_C < \kappa_B < \kappa_A$

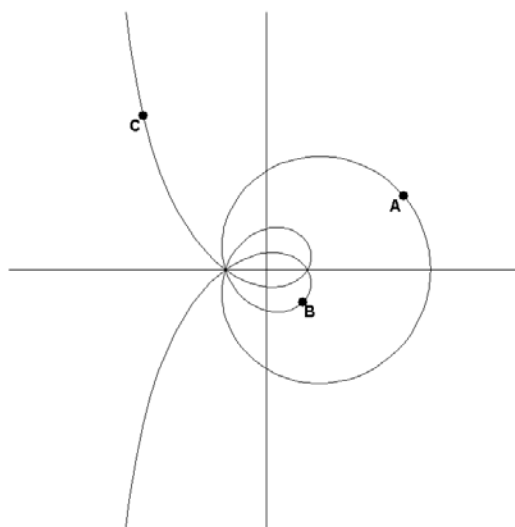

2. Let  $D$  be the region of the plane consisting of Cartesian coordinates  $(x, y)$  with  $y > 0$  and all  $-\infty < x < \infty$ . Which of the following is the correct description of the region  $D$  using polar coordinates?

- ①  $\theta > 0, -\infty < r < \infty$   
 ②  $0 < \theta < \pi, r > 0$   
 ③  $-\pi < \theta < \pi, r > 0$   
 ④  $-\pi/2 < \theta < \pi/2, -\infty < r < \infty$

3. Suppose that the line  $\ell$  whose parametric equations are given below is perpendicular to a plane. A point  $P(3, 2, 4)$  lies in the plane. Find the coordinates of the point  $Q$  that lies both on the line  $\ell$  and in the plane.

$$\ell \begin{cases} x = 10 + 2t \\ y = -4 - 3t \\ z = t \\ -\infty < t < \infty \end{cases}$$

- ①  $Q(10, -4, 0)$   
 ②  $Q(2, -2, -6)$   
 ③  $Q(14, -10, 2)$   
 ④  $Q(6, 2, -2)$
4. Which of the following parameterizations traverses the top half ( $y \geq 0$ ) of a circle of radius 2 centered at the origin, in a counterclockwise direction?

- ①  $x(t) = 2 \sin(4t), y(t) = 2 \cos(4t), 0 \leq t \leq \pi/4.$   
 ②  $x(t) = 2 \cos(4t), y(t) = 2 \sin(4t), 0 \leq t \leq \pi.$   
 ③  $x(t) = 2 \cos(4t), y(t) = 2 \sin(4t), 0 \leq t \leq \pi/4.$   
 ④  $x(t) = 2 \cos(4t), y(t) = -2 \sin(4t), 0 \leq t \leq \pi.$

5. If  $\vec{a} = \langle 3, -2, 1 \rangle$  and  $\vec{b} = \langle 2, 1, 2 \rangle$ , then the angle between  $\vec{a}$  and  $\vec{b}$  is

- ①  $\cos^{-1}\left(\frac{2}{\sqrt{14}}\right)$   
 ②  $\cos^{-1}\left(\frac{\sqrt{14}}{2}\right)$   
 ③  $\cos^{-1}(18\sqrt{14})$   
 ④  $\cos^{-1}\left(\frac{18}{\sqrt{14}}\right)$

6.  $\vec{r}(t) = \langle 6t, 3\sqrt{2}t^2, 2t^3 \rangle$  describes a particle's motion along a space curve. Given that  $\left\| \frac{d\vec{r}}{dt} \right\| = 6 + 6t^2$  m/s, what is the distance traveled by the particle between the points  $(6, 3\sqrt{2}, 2)$  and  $(12, 12\sqrt{2}, 16)$ ?

- ① 8 meters  
 ② 20 meters  
 ③  $\frac{10}{3}$  meters  
 ④  $\sqrt{394} \approx 19.85$  meters

7. Given the polar equation  $\tan(\theta) = 4r \cos(\theta)$ , which of the following is its Cartesian equivalent?

①  $y = 4x^2$

②  $y = 4x$

③  $\tan(y) = 4(x^2 + y^2)$

④  $x^2 + y^2 = 4$

8. Which of the following is the area of the triangle  $ABC$  where  $A(1, 0, 0)$ ,  $B(2, 0, -1)$ , and  $C(1, 4, 3)$ ?

①  $\sqrt{11}$

②  $\frac{\sqrt{11}}{2}$

③  $\sqrt{41}$

④  $\frac{\sqrt{41}}{2}$

9. Given a particle traveling along a circular path with constant speed  $4 \text{ ft/s}$  and an acceleration vector valued function with  $\|a(\vec{t})\| = 9 \text{ ft/s}^2$  at any given time  $t$ . What is the radius of the circle?

①  $\frac{16}{9}$  feet

②  $\frac{9}{16}$  feet

③ 144 feet

④ 36 feet

10. A cannon sits on top of a hill overlooking a level field. The cannon is at an elevation of 264 feet relative to the field, and fires a cannonball at  $80 \text{ ft/s}$  at an angle of  $30^\circ$  with the horizontal. What is the range of the cannonball, assuming ideal projectile motion?

①  $100\sqrt{3}$  feet

②  $120\sqrt{3}$  feet

③  $220\sqrt{3}$  feet

④ 264 feet

11. Write the complex number  $\frac{2}{i}(3 + i)$  in the form  $a + bi$  with  $a, b \in \mathbb{R}$ .
- ① 8
  - ②  $2 - 6i$
  - ③  $6 - 2i$
  - ④  $6 + 2i$
12. Let  $\vec{c} = \vec{a} \times \vec{b}$ . If  $\vec{a} = \langle a_1, a_2, a_3 \rangle$ ,  $\vec{b} = \langle 1, 1, 0 \rangle$ ,  $\vec{c} = \langle -2, 2, -1 \rangle$  and  $|\vec{a}| = \sqrt{5}$  then which of the following vectors could be  $\vec{a}$ ?
- ①  $\vec{a} = \langle 2, 3, 2 \rangle$
  - ②  $\vec{a} = \langle 1, 0, 2 \rangle$
  - ③  $\vec{a} = \langle -1, 0, 2 \rangle$
  - ④  $\vec{a} = \langle 0, -1, 2 \rangle$
13.  $\left(\frac{1}{\sqrt{2}} - \frac{i}{\sqrt{2}}\right)^{24}$  equals
- ①  $\frac{1}{4096} - \frac{i}{4096}$
  - ②  $-1$
  - ③  $\frac{1}{\sqrt{2}} + \frac{i}{\sqrt{2}}$
  - ④ 1
14. Which of the following equations describes a plane that passes through the point  $(-2, 1, 4)$  and is parallel to the plane  $x - 2y + 5z = 3$ ?
- ①  $x - 2y + 5z = 16$
  - ②  $x - 2y + 5z = 20$
  - ③  $-2x + y + 4z = 21$
  - ④  $-2x + y + 4z = 3$

15. The velocity of a particle traveling along a space curve is modeled by

$$\vec{v}(t) = \langle 3t^2, 1 - 2t, e^t \rangle$$

The initial velocity vector is  $v_o = \langle 0, 1, 1 \rangle$ . The initial position of the particle was at the point  $(2, 1, 2)$  when  $t = 0$ . What is the vector-valued function of position at time  $t$ ,  $\vec{r}(t)$ ?

- ①  $\vec{r}(t) = \langle t^3, t - t^2, e^t \rangle$   
 ②  $\vec{r}(t) = \langle t^3 + 2, t - t^2 + 1, e^t + 2 \rangle$   
 ③  $\vec{r}(t) = \langle t^3, 1 + t - t^2, 1 + e^t \rangle$   
 ④  $\vec{r}(t) = \langle t^3 + 2, 1 + t - t^2, 1 + e^t \rangle$

16. Two tugboats tow a ship into port, as shown in the figure. The larger tug exerts a constant force of 4000 pounds on its cable, and the smaller tug exerts a constant force of 3200 pounds on its cable. If the ship is to travel in a straight line from  $A$  to  $B$ , then the angle  $\theta$  that the larger tug must make with the line segment  $AB$  is

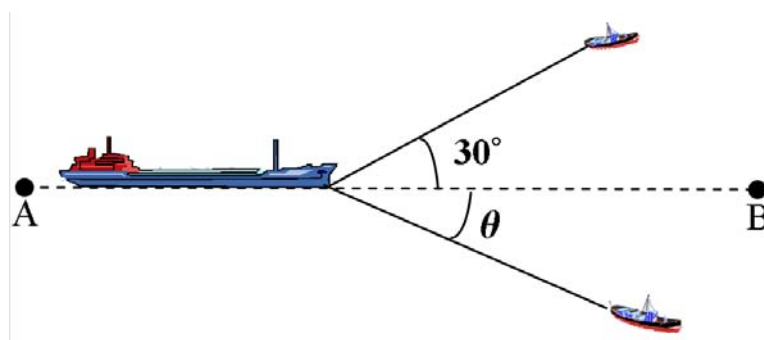

- ①  $\theta = \cos^{-1} \left( \frac{2\sqrt{3}}{5} \right) \approx 46.14^\circ$   
 ②  $\theta = \sin^{-1} \left( \frac{2\sqrt{3}}{5} \right) \approx 43.85^\circ$   
 ③  $\theta = \sin^{-1} \left( \frac{2}{5} \right) \approx 23.58^\circ$   
 ④  $\theta = \tan^{-1} \left( \frac{4}{5} \right) \approx 38.66^\circ$